



PARTS MANUAL

MODEL EMP 255ic & EMP 320ic



Valid for: serial nos. 730-xxx-xxxx, 735-xxx-xxxx

Rights reserved to alter specifications without notice.

(Intentionally Blank)



EU DECLARATION OF CONFORMITY

According to
The Low Voltage Directive 2014/35/EU, entering into force 20 April 2016
The EMC Directive 2014/30/EU, entering into force 20 April 2016
The RoHS Directive 2011/65/EU, entering into force 2 January 2013

Type of equipment
Welding power source

Type designation

EMP 320ic, from serial number 730 xxx xxxx (2017 w30)
EMP 255ic, from serial number 735 xxx xxxx (2017 w35)

Brand name or trade mark
ESAB

Manufacturer or his authorised representative established within the EEA

Name, address, and telephone No:

ESAB AB
Lindholmsallén 9, Box 8004, SE-402 77 Gothenburg, Sweden
Phone: +46 31 50 90 00, Fax: +46 31 50 92 22

The following harmonised standard in force within the EEA has been used in the design:

EN 60974-1:2012, Arc Welding Equipment – Part 1: Welding Power Sources
EN 60974-5:2013, Arc Welding Equipment – Part 5: Wire Feeders
EN 60974-10:2014, A1:2015 Arc Welding Equipment – Part 10: Electromagnetic Compatibility (EMC) requirements

Additional information:

Restrictive use, Class A equipment, intended for use in location other than residential

By signing this document, the undersigned declares as manufacturer, or the manufacturer's authorised representative established within the EEA, that the equipment in question complies with the safety requirements stated above.

Date

Gothenburg

2018-02-27

Signature

Pedro Muniz

Position

Standard Equipment Director

CE 2018

This PARTS MANUAL is written for the ESAB Welder models EMP 255ic and EMP 320ic. The Part # for each of these welders is given here. Individual Parts/Assemblies are given in this manual.

Part #	Product Name
0700 300 992	EMP 255ic
0700 300 991	EMP 320ic

Spare parts are to be ordered through the nearest ESAB agency. Indicate type of unit, serial number, product name, and part numbers according to a spare parts list.

WARNING

Maintenance and repair work should be performed by an experienced person, and electrical work only by a trained electrician. Use only recommended spare parts.

SECTION TABLE OF CONTENTS

Paragraph		Page
SECTION 1 HOUSING PARTS		
1.1	HOUSING PARTS.....	1-1
SECTION 2 CONNECTION PARTS		
2.1	CONNECTION PARTS.....	2-1
SECTION 3 USER-INTERFACE PARTS		
3.1	USER-INTERFACE PARTS.....	3-1
SECTION 4 CONTROL/POWER MODULES PARTS		
4.1	CONTROL/POWER MODULES PARTS	4-1
SECTION 5 WIRE-FEED ASSEMBLY PARTS		
5.1	WIRE-FEED ASSEMBLY PARTS	5-1

SECTION LIST OF FIGURES

Figure	Page
Figure 1-1. Housing	1-2
Figure 2-1. Connections	2-2
Figure 3-1. User-Interface	3-2
Figure 4-1. Control Modules	4-2
Figure 5-1. Wire-Feed Assembly	5-3

SECTION LIST OF TABLES

Table	Page
Table 1-1. Housing Parts	1-1
Table 2-1. Connection Parts	2-1
Table 3-1. User-Interface Parts	3-1
Table 4-1. Control/Power Modules Parts	4-1
Table 5-1. Wire-Feed Assembly Parts	5-1
Table 5-2. PART # 17 Wire-Feed Rollers: Available Sizes for Models 255ic or 320ic	5-1
Table 5-3. Output & Center Wire-Guide Tube: Available Sizes for Models 255ic or 320ic	5-2

HOUSING PARTS

SECTION 1

HOUSING PARTS

1.1 HOUSING PARTS

Table 1-1. Housing Parts

Item	Part #	Description	Qty
1	0558 102 537	Hinge	1
2	0558 102 538	Door pull & latch	1
3	0464 651 880	Side door, spool side (EMP 255ic)	1
	0464 651 881	Side door, spool side (EMP 320ic)	
4	0558 102 544	Side frame, spool side	1
5	0558 102 399	Handle	4
6	0558 102 545	Foot (With 2× M6x20 screw)	2
7	0558 102 547	Side door, power side	1
8	0558 102 546	Side frame, power side	1

HOUSING PARTS

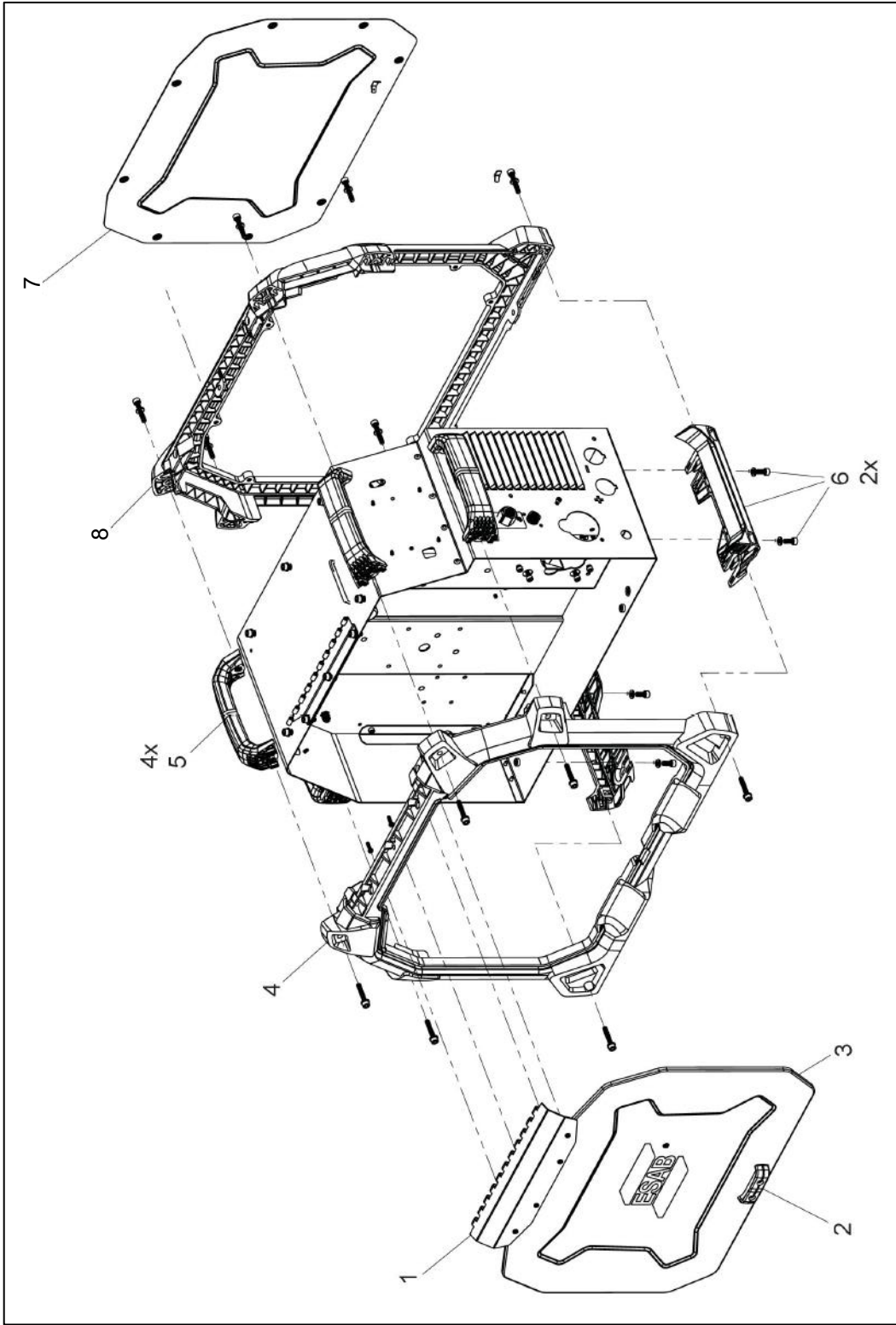

Figure 1-1. Housing

CONNECTION PARTS

SECTION 2

CONNECTION PARTS

2.1 CONNECTION PARTS

Table 2-1. Connection Parts

Item	Part #	Description	Qty
1	0558 102 521	Brake hub kit	1
2	0464 620 880	MIG gas solenoid system	1
3	0464 621 880	TIG/Spool gun gas solenoid system	1
4	0558 102 525	Bracket, gas solenoid mounting	1
5	0464 622 880	Gas inlet/outlet, bulkhead fitting	2
12	0464 637 880	Gas inlet/outlet, bulkhead fitting - BSP	1
6	0464 646 880	Power switch	1
7	0464 639 880	Fan Bracket assembly	1
8	0558 102 527	Female OKC connector	2
9	0558 102 593	Polarity change cable & male OKC connector	1
10	0464 663 020	Euro adapter assembly	1
11	0558 102 530	8 pin female remote receptacle and harness	1
12	0464 640 880	Wire drive assembly, Euro connector	1

CONNECTION PARTS

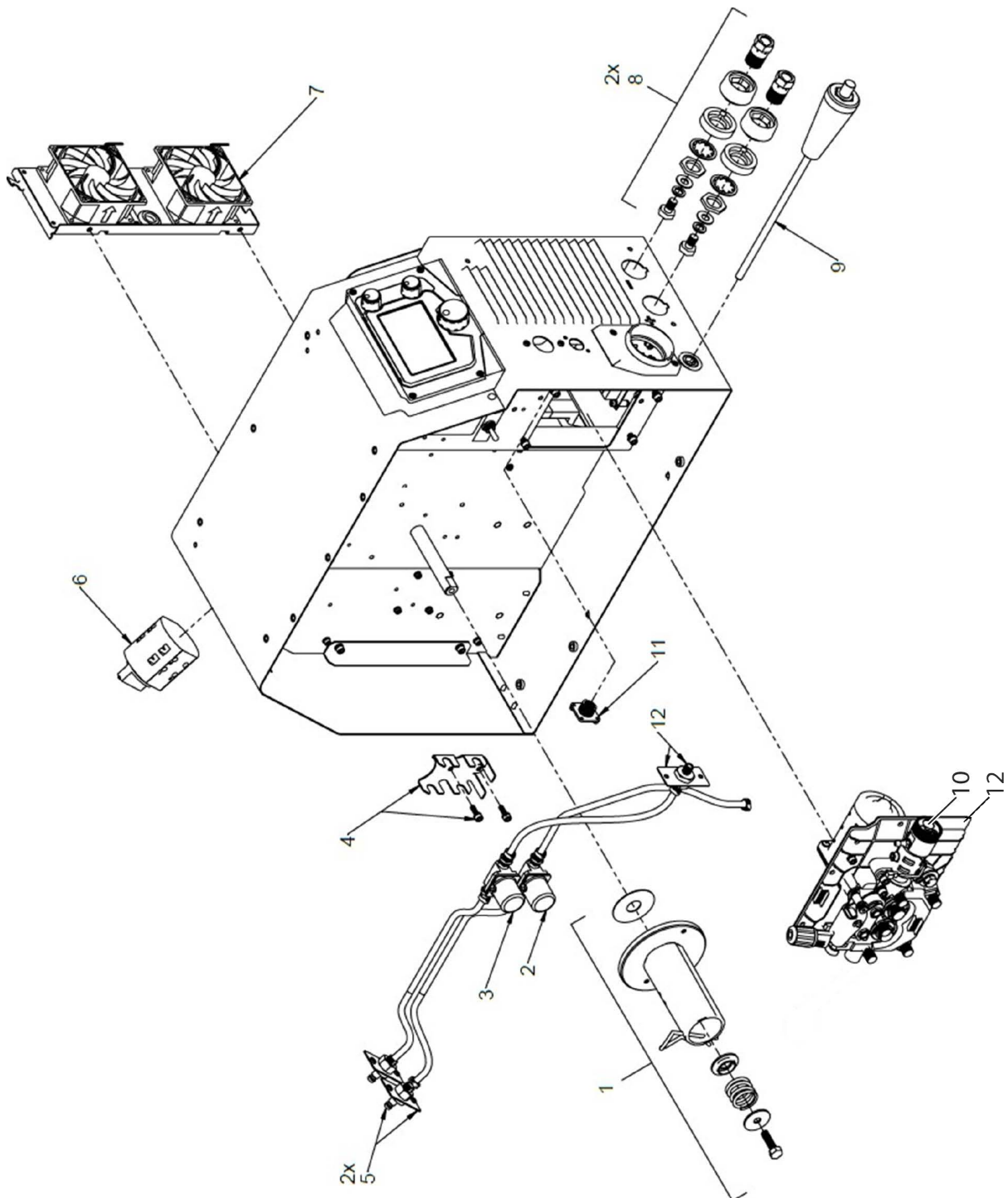

Figure 2-1. Connections

USER-INTERFACE PARTS

SECTION 3

USER-INTERFACE PARTS

3.1 USER-INTERFACE PARTS

Table 3-1. User-Interface Parts

EMP 255ic

Item	Part #	Description	Qty
1	0464 649 880	User interface complete	1
2	0558 102 438	Replaceable display lens	1
3	0558 102 423	Encoder for small knob	2
4	0558 102 424	Encoder for large knob	1
5	0558 102 440	Knob, small	2
6	0558 102 441	Knob, large	1
7	0464 647 880	Lens assembly kit	1

EMP 320ic

Item	Part #	Description	Qty
1	0464 650 880	User interface complete	1
2	0558 102 438	Replaceable display lens	1
3	0558 102 423	Encoder for small knob	2
4	0558 102 424	Encoder for large knob	1
5	0558 102 440	Knob, small	2
6	0558 102 441	Knob, large	1
7	0464 648 880	Lens assembly kit	1

USER-INTERFACE PARTS

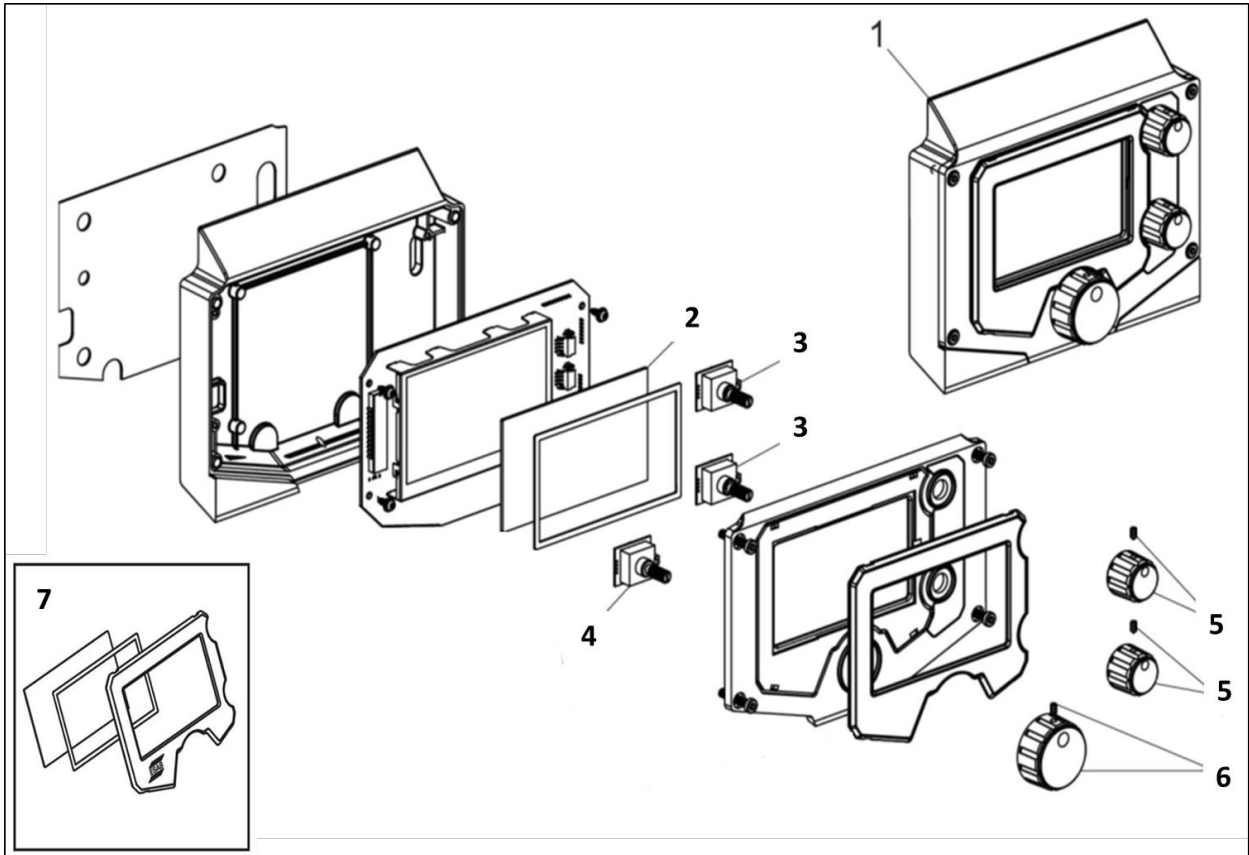

Figure 3-1. User-Interface

CONTROL/POWER-MODULE PARTS

SECTION 4

CONTROL/POWER MODULE PARTS

4.1 CONTROL/POWER MODULES PARTS

Table 4-1. Control/Power Modules Parts

Item	Part #	Description	Qty
1	0464 592 880	Control PCB	1
2	0464 643 880	Main Power Board Assembly	1
3	0558 102 595	Output Inductor	1
4	0558 102 596	Output Diode Assembly	1
5	0464 644 880	Main Transformer	1
6	0464 642 880	IPS Board Assembly	1
7	0558 102 535	Strain relief, mains cable	1
8	0464 645 880	Mains Cable	1
9	0464 641 880	EMI Filter Board Assembly	1

CONTROL/POWER-MODULE PARTS

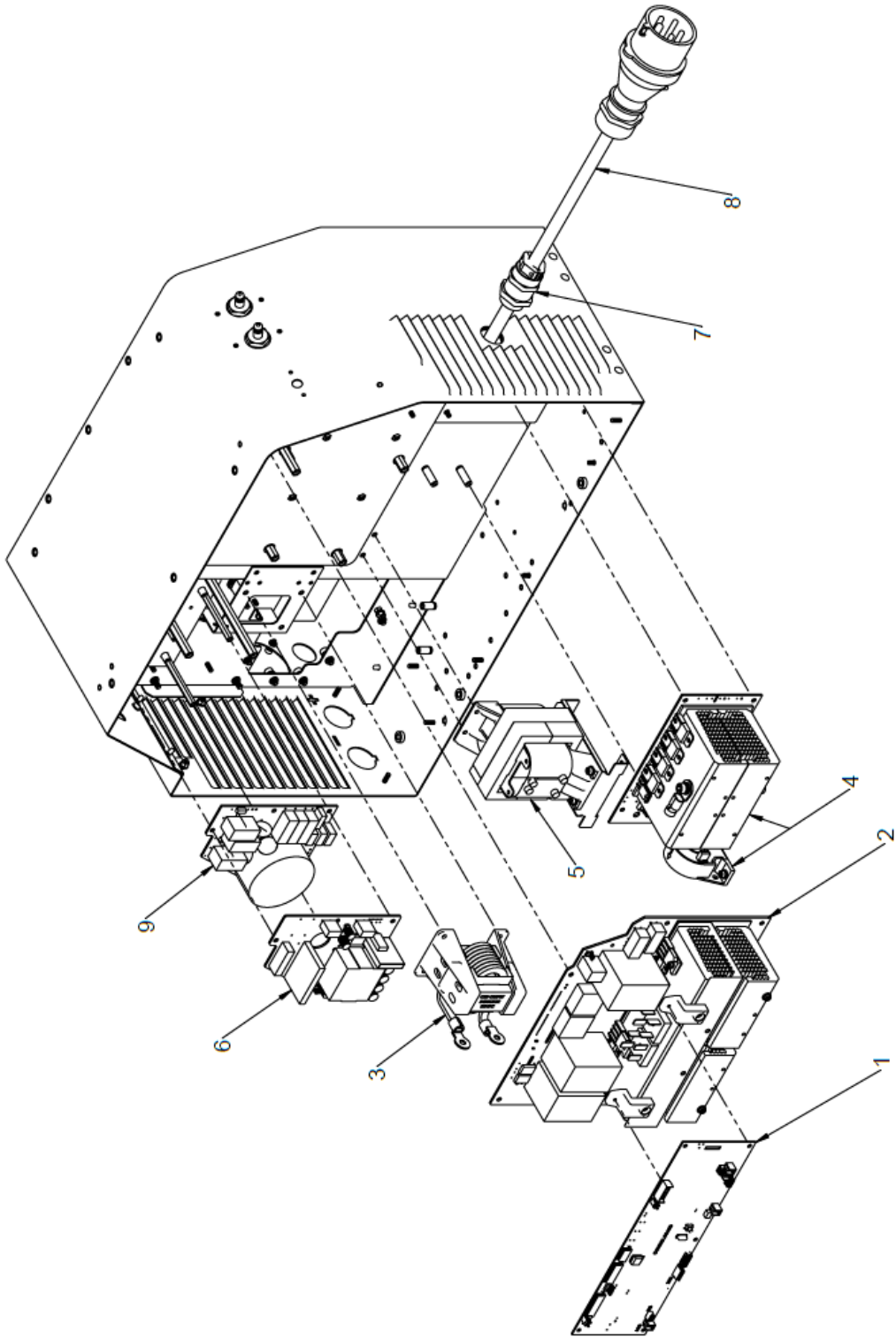

Figure 4-1. Control Modules

WIRE-FEED ASSEMBLY PARTS

SECTION 5

WIRE-FEED ASSEMBLY PARTS

5.1 WIRE-FEED ASSEMBLY PARTS

Table 5-1. Wire-Feed Assembly Parts

Item	Part #	DESCRIPTION	Qty
1	0558102591	PRESSURE ROLLER ASSEMBLY	1
2	0558102592	TENSION ADJUSTMENT ASSEMBLY	1
3	0558102608	CENTER WIRE-GUIDE TUBE	1
3	0558102643	CENTER WIRE-GUIDE TUBE, ALUMINUM	1
4	(SEE BELOW)	OUTPUT WIRE-GUIDE TUBE	1
5	0558102609	MOTOR-GEAR SHAFT WOODRUFF KEY	1
6	0558102597	INLET QUAD WF	1
7	0558102605	DRIVEN GEAR ASSEMBLY	2
8	0558102606	DRIVE GEAR ASSEMBLY	1
9	(SEE BELOW)	WIRE-FEED ROLLERS	2
10	0558102600	WASHER FLAT M4 LARGE OD	3
11	0558102601	THUMB SCREW M4 X 10 X 8 KNURLED	1
12	0558102602	THUMB SCREW M4 X 10 KNURLED	2
13	055810603	QUAD WF COVER	1
14	0558102604	THUMB SCREW M5 X 14 KNURLED	5
15	0464663326	AXLE FOR FEED ROLLER	2

Table 5-2. PART # 17 Wire-Feed Rollers: Available Sizes for Models 255ic or 320ic

ITEM #	PART #	DESCRIPTION (Values = Wire Diameter)	COMMENT
FEED ROLLERS FOR ALL WIRES EXCEPT ALUMINUM			
1	0369557003	ROLLER, .040 (1.0) - .045 (1.2), V-SOLID	DEFAULT*
2	0369557002	ROLLER, .030 (.8) - .040 (1.0), V-SOLID	ACCESSORY**
3	0369557001	ROLLER, .024 (.6) - .030 (.8), V-SOLID	OPTIONAL FOR PURCHASE
4	0369557013	ROLLER, .052 (1.4) - .062 (1.6), V-SOLID	OPTIONAL FOR PURCHASE
FEED ROLLERS FOR ALUMINUM WIRE			
5	0369557006	ROLLER, .040 (1.0) - .045 (1.2), ALUM (U-GROOVE)	OPTIONAL FOR PURCHASE
6	0369557011	ROLLER, .030 (0.8) - .040 (1.0), ALUM (U-GROOVE)	OPTIONAL FOR PURCHASE
* DEFAULT (size included in package)			
** ACCESSORY (included with each model 255 or 320 unit.)			

WIRE-FEED ASSEMBLY PARTS

Table 5-3. Output & Center Wire-Guide Tube: Available Sizes for Models 255ic or 320ic

ITEM #	PART #	DESCRIPTION (Values = Inner Diameter (ID) of Tubes)	COMMENT
OUTPUT WIRE-GUIDE TUBES EXCEPT FOR ALUMINUM WIRE			
1	0464652880	TUBE, WIRE GUIDE .040 (1.0) - .045 (1.2), V-SOLID	DEFAULT*
2	0464653880	TUBE, WIRE GUIDE .030 (.8) - .040 (1.0), V-SOLID	ACCESSORY**
3	0464657880	TUBE, WIRE GUIDE .024 (.6), V-SOLID	OPTIONAL FOR PURCHASE
4	0464658880	TUBE, WIRE GUIDE .052 (1.4) - .062 (1.6), V-SOLID	OPTIONAL FOR PURCHASE
OUTPUT WIRE-GUIDE TUBES FOR ALUMINUM WIRE			
5	0464660880	TUBE, WIRE GUIDE .040 (1.0) - .045 (1.2), ALUM	OPTIONAL FOR PURCHASE
6	0464661880	TUBE, WIRE GUIDE .052 (1.4) - .062 (1.6), ALUM	OPTIONAL FOR PURCHASE
* DEFAULT (size included in package)			
** ACCESSORY (optional size included with each model 255 or 320 unit)			

WIRE-FEED ASSEMBLY PARTS

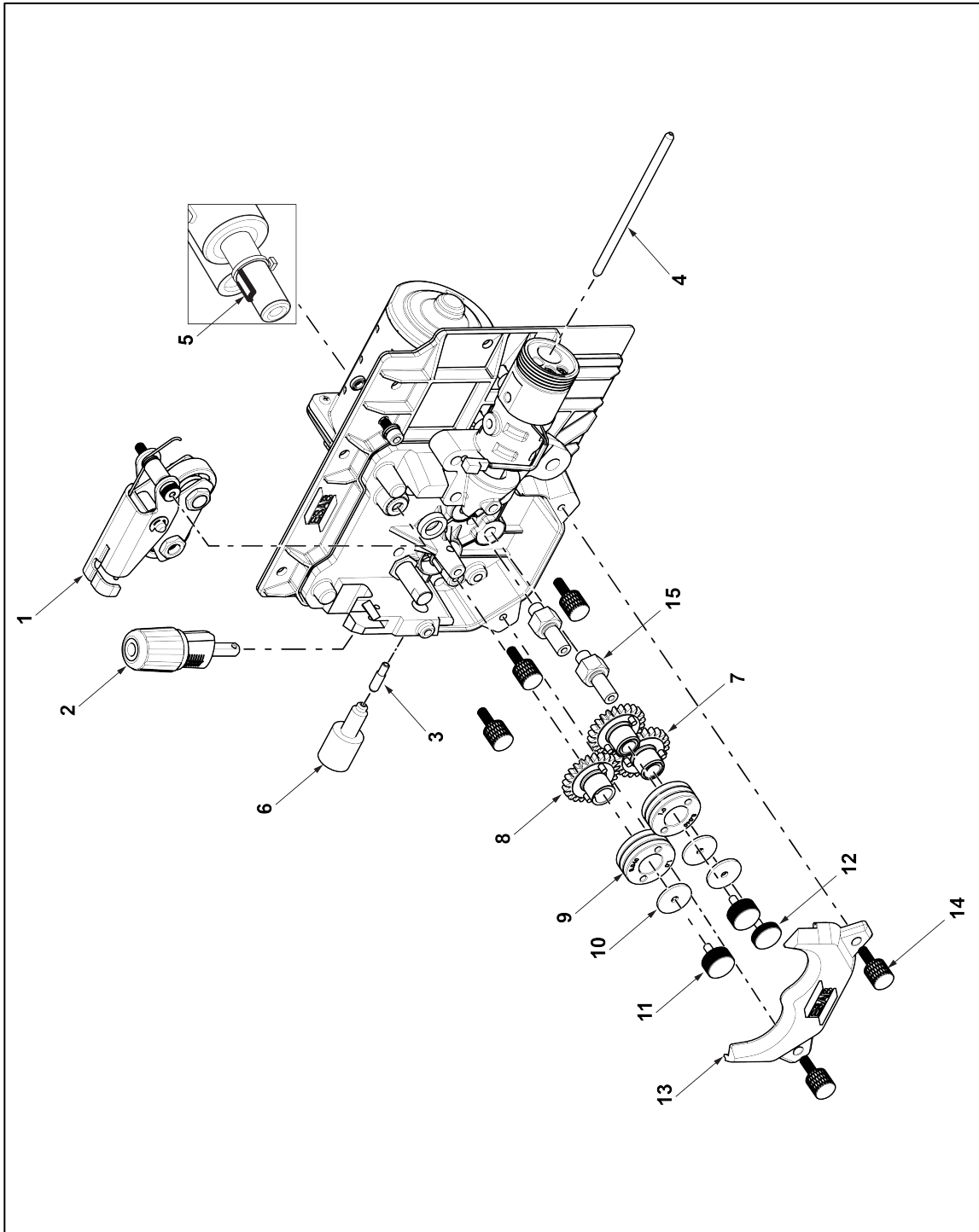

Figure 5-1. Wire-Feed Assembly

WIRE-FEED ASSEMBLY PARTS

(Intentionally Blank)

ESAB Subsidiaries and Representative Offices

AUSTRIA

ESAB Ges.m.b.H
Vienna-Liesing
Tel: +43 1 888 25 11
Fax: +43 1 888 25 11 85

BELGIUM

S.A. ESAB N.V. Heist-
op-den-Berg Tel: +32
15 25 79 30 Fax: +32
15 25 79 44

BULGARIA

ESAB Kft Representative Office
Sofia
Tel: +359 2 974 42 88
Fax: +359 2 974 42 88

THE CZECH REPUBLIC

ESAB VAMBERK s.r.o.
Vamberk
Tel: +420 2 819 40 885
Fax: +420 2 819 40 120

DENMARK

Aktieselskabet ESAB
Herlev
Tel: +45 36 30 01 11
Fax: +45 36 30 40 03

FINLAND

ESAB Oy
Helsinki
Tel: +358 9 547 761
Fax: +358 9 547 77 71

GREAT BRITAIN

ESAB Group (UK) Ltd
Waltham Cross
Tel: +44 1992 76 85 15
Fax: +44 1992 71 58 03

ESAB Automation Ltd
Andover

Tel: +44 1264 33 22 33
Fax: +44 1264 33 20 74

FRANCE

ESAB France S.A.
Cergy Pontoise
Tel: +33 1 30 75 55 00
Fax: +33 1 30 75 55 24

GERMANY

ESAB Welding & Cutting GmbH
Langenfeld
Tel: +49 2173 3945-0
Fax: +49 2173 3945-218

HUNGARY

ESAB Kft
Budapest
Tel: +36 1 20 44 182
Fax: +36 1 20 44 186

ITALY

ESAB Saldatura S.p.A. Bareggio
(Mi)
Tel: +39 02 97 96 8.1
Fax: +39 02 97 96 87 01

THE NETHERLANDS

ESAB Nederland B.V.
Amersfoort
Tel: +31 33 422 35 55
Fax: +31 33 422 35 44

NORWAY

AS ESAB
Larvik
Tel: +47 33 12 10 00
Fax: +47 33 11 52 03

POLAND

ESAB Sp.zo.o. Katowice
Tel: +48 32 351 11 00
Fax: +48 32 351 11 20

PORTUGAL

ESAB Lda
Lisbon
Tel: +351 8 310 960
Fax: +351 1 859 1277

ROMANIA

ESAB Romania Trading SRL
Bucharest
Tel: +40 316 900 600
Fax: +40 316 900 601

RUSSIA

LLC ESAB
Moscow
Tel: +7 (495) 663 20 08
Fax: +7 (495) 663 20 09

SLOVAKIA

ESAB Slovakia s.r.o. Bratislava
Tel: +421 7 44 88 24 26
Fax: +421 7 44 88 87 41

SPAIN

ESAB Ibérica S.A.
San Fernando de Henares
(MADRID)
Tel: +34 91 878 3600
Fax: +34 91 802 3461

SWEDEN

ESAB Sverige AB Gothenburg
Tel: +46 31 50 95 00
Fax: +46 31 50 92 22

ESAB International AB
Gothenburg
Tel: +46 31 50 90 00
Fax: +46 31 50 93 60

SWITZERLAND

ESAB Europe GmbH Baar
Tel: +41 1 741 25 25
Fax: +41 1 740 30 55

UKRAINE

ESAB Ukraine LLC Kiev
Tel: +38 (044) 501 23 24
Fax: +38 (044) 575 21 88
North and South America

ARGENTINA

CONARCO
Buenos Aires
Tel: +54 11 4 753 4039
Fax: +54 11 4 753 6313

BRAZIL

ESAB S.A.
Contagem-MG
Tel: +55 31 2191 4333
Fax: +55 31 2191 4440

CANADA

ESAB Group Canada Inc.
Mississauga, Ontario
Tel: +1 905 670 0220
Fax: +1 905 670 4879

MEXICO

ESAB Mexico S.A.
Monterrey
Tel: +52 8 350 5959
Fax: +52 8 350 7554

USA

ESAB Welding & Cutting
Products
Florence, SC
Tel: +1 843 669 4411
Fax: +1 843 664 5748

Asia/Pacific

AUSTRALIA

ESAB South Pacific
Archerfield BC QLD 4108
Tel: +61 1300 372 228
Fax: +61 7 3711 2328

CHINA

Shanghai ESAB A/P
Shanghai
Tel: +86 21 2326 3000
Fax: +86 21 6566 6622

INDIA

ESAB India Ltd
Calcutta
Tel: +91 33 478 45 17
Fax: +91 33 468 18 80

INDONESIA

P.T. ESABindo
Pratama Jakarta
Tel: +62 21 460 0188
Fax: +62 21 461 2929

JAPAN

ESAB Japan
Tokyo

Tel: +81 45 670 7073
Fax: +81 45 670 7001

MALAYSIA

ESAB (Malaysia) Snd Bhd
USJ
Tel: +603 8023 7835
Fax: +603 8023 0225

SINGAPORE

ESAB Asia/Pacific Pte Ltd
Singapore
Tel: +65 6861 43 22
Fax: +65 6861 31 95
SOUTH KOREA
ESAB SeAH
Corporation
Kyungnam
Tel: +82 55 269 8170
Fax: +82 55 289 8864

UNITED ARAB EMIRATES

ESAB Middle East FZE
Dubai
Tel: +971 4 887 21 11
Fax: +971 4 887 22 63

Africa

EGYPT

ESAB
Egypt
Dokki-
Cairo
Tel: +20 2 390 96 69
Fax: +20 2 393 32 13

SOUTH AFRICA

ESAB Africa Welding &
Cutting Ltd
Durbanvill 7570 - Cape
Town Tel: +27 (0)21 975
8924

Distributors

*For addresses and phone
numbers to our
distributors in other
countries, please visit our
home page
www.esab.com*



www.esab.com

